

STAGES	RATIO i (CATALOG)	F <sub>R</sub>	F <sub>A</sub>	F <sub>M</sub>	T <sub>MAX</sub>	( L )
1	4:1	240 N	70 N	1000 N	800 Ncm	176,1
2	14:1 / 19:1 / 25:1	360 N	100 N	1000 N	2500 Ncm	193
3	71:1 / 100:1 / 130:1 / 169:1	520 N	150 N	1000 N	5000 Ncm	210

F<sub>R</sub> - ALLOWED RADIAL FORCE MIDDLE OUTPUT SHAFT FROM MOUNTING SURFACE

F<sub>A</sub> - ALLOWED AXIAL FORCE

F<sub>M</sub> - ALLOWED MOUNTING FORCE FOR ADD-ON PARTS

T<sub>MAX</sub> - ALLOWED TORQUE

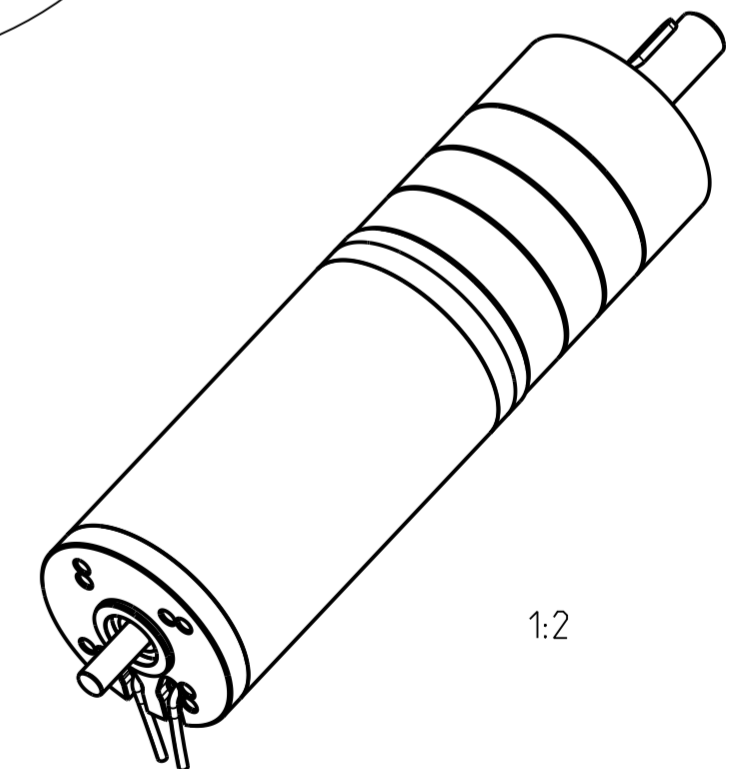
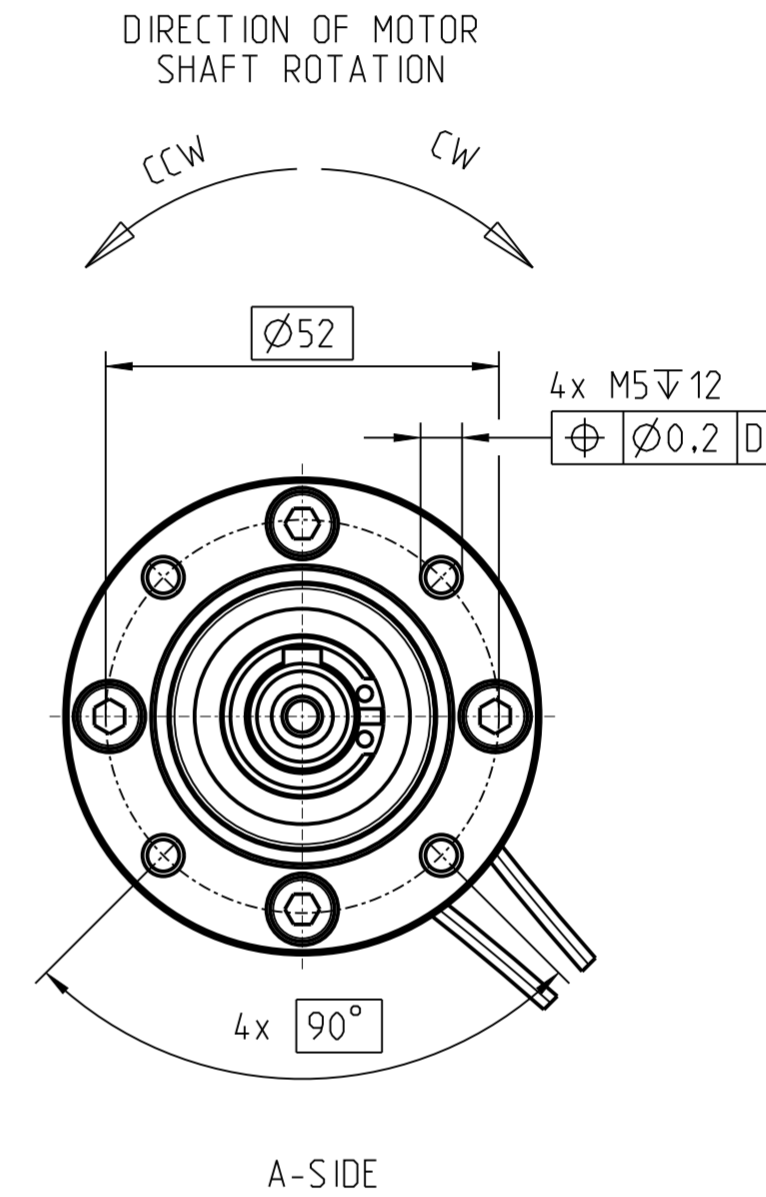
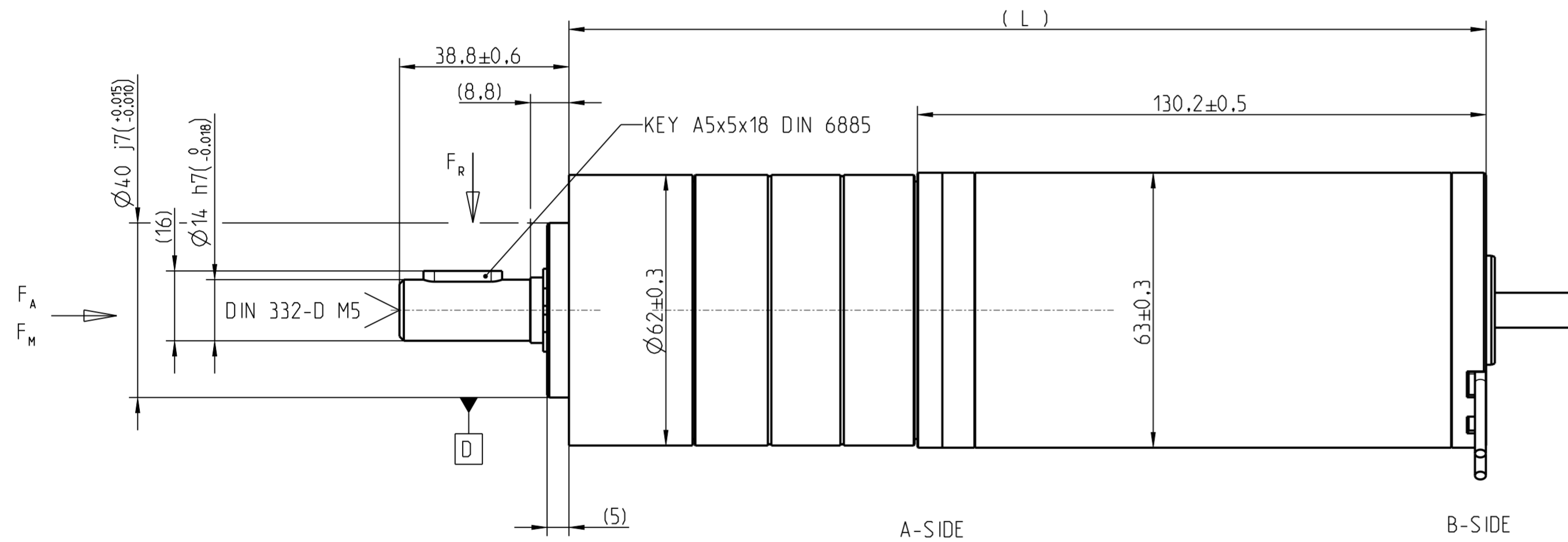

GENERAL TOLERANCES		MATERIAL		WT-PART NUMBER	
-		PLANETARY GEARBOX PLG62		13010706	
TOLERANCING				CREATED	
ISO 8015				M.Semmlinger	
THEORETICAL MASS		CHANGE DESCRIPTION		CHANGE NUMBER	
(233.032 g)		0x ② EDITORIAL CHANGES		APPROVED	
SCALE		SIZE		PREVIOUS VERSION	
1:1		DIN A2		-	
Bühler Motor		Bühler		DOCUMENT STATE	
		TITLE		DOCUMENT REVISION	
		bMotion		13010705 2	
		PMDC 63x125		DATE OF ISSUE SHEET	
				2024-05-22 3/10	
DIMENSIONS IN mm		ENGLISH WORDING IS BINDING		ASSEM. DRAWING	

THE REPRODUCTION, DISTRIBUTION AND UTILIZATION OF THIS DOCUMENT AS WELL AS THE  
 CONSTRUCTION OF IDENTICAL OR SIMILAR DEVICES WITHOUT EXPRESS WRITTEN PERMISSION IS  
 PROHIBITED. OFFENDERS WILL BE HELD LIABLE FOR THE PAYMENT OF DAMAGES. ALL  
 RIGHTS RESERVED IN THE EVENT OF THE GRANT OF A PATENT. UTILITY MODEL OR DESIGN.  
 FIRST ANGLE PROJECTION  
 Projektionsmethode 1

Weitergabe sowie Vervielfältigung dieses Dokuments, Verwertung und  
 Verbreitung, auch auszugsweise, ist ohne schriftliche Genehmigung der  
 Bühler Group. Die Weitergabe, Vervielfältigung, Verbreitung, auch  
 auszugsweise, ist ohne schriftliche Genehmigung der Bühler Group.  
 All rights reserved. No part of this publication may be reproduced, stored in a  
 retrieval system, or transmitted, in any form or by any means, electronic, mechanical,  
 photocopying, recording, or by any information storage or retrieval system, without  
 prior written permission from Bühler Group.